

SOLDER IN THE DIODE IN THE LEAD GOING TO THE "RIGHT" SIDE OF THE GUIDE
 MAKE SURE THE GRAY BAND OF THE DIODE IS TOWARDS THE MOTOR
 INLINE OR SIDEWINDER MOTOR MOUNT IS TREATED THE SAME

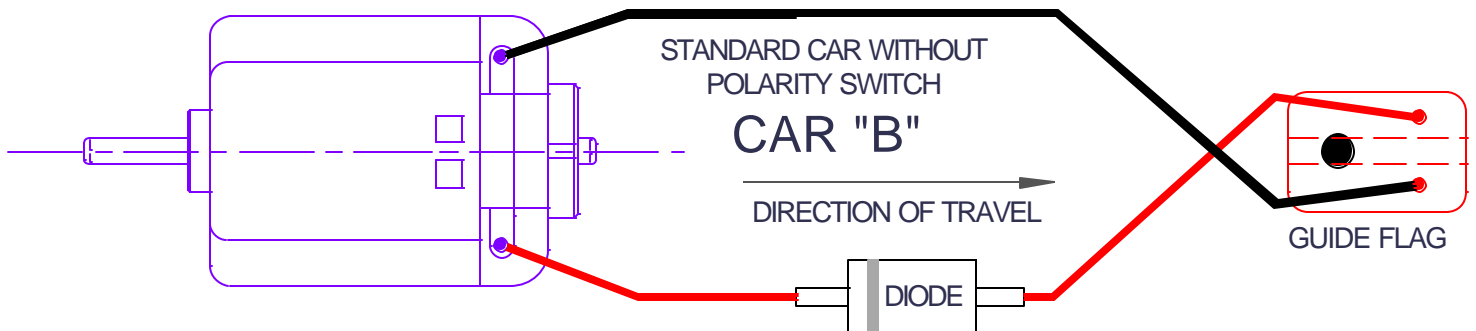

SOLDER IN THE DIODE SAME AS IN "A" ABOVE
 SWITCH THE LEAD WIRES AT THE GUIDE FLAG
 INLINE OR SIDEWINDER MOTOR MOUNT IS TREATED THE SAME

CARRERA CAR "A" & "B" WITH POLARITY SWITCH

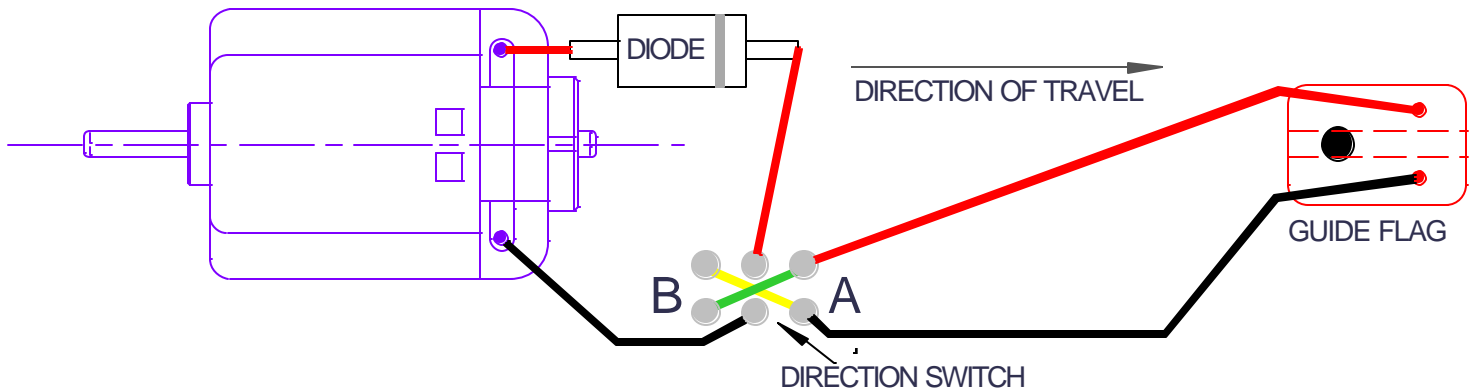

SOLDER IN THE DIODE IN THE LEAD GOING TO THE "LEFT" SIDE OF THE MOTOR
 MAKE SURE THE GRAY BAND OF THE DIODE IS AWAY FROM THE MOTOR
 DIRECTION SWITCH POSITION TO REAR OF CAR IS "B", TOWARDS FRONT IS "A"
 INLINE OR SIDEWINDER MOTOR MOUNT IS TREATED THE SAME